

CATALOG COLLECTION	LET'S PLAY TOGETHER
DIMENSIONS (L x W x H) in cm	950 x 690 x 400
MAXIMUM CFH	80
IMPACT ATTENUATING SURFACE	min. 114,50 m ² - MAX 125,00 m ²
SUGGESTED AGE OF USE	3 - 12
COMPOSITION	<ul style="list-style-type: none"> - n°18 Ø127mm aluminium poles - n°11 aluminium decks - n°1 aluminium sheet pyramid roof - n°3 metal guardpanels - n°3 HDPE sheet guardpanels - n°8 metal tubular and HDPE guardpanels - n°1 aluminium sheet stairs - n°1 modular slide - n°1 tube slide - n°1 rotating mold PTE and HDPE sheet tunnel - n°6 HDPE sheet playpanels

SECURITY AREA
1000

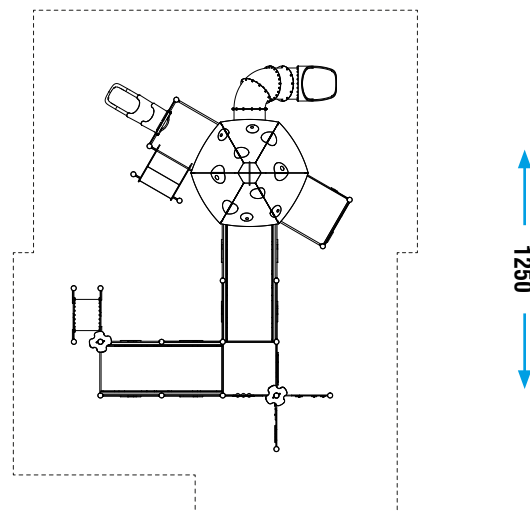

Make a proper security surface according to CFH. **Periodic maintenance is mandatory**, following manual supplied to customer.