

ROBINIA RB1308



1+



5 kids



23,2 m²



Material specification

- Construction made of Robinia - very durable acacia wood with a diameter of ~ 18 cm without sharp edges, resistant to weather conditions,
- Platforms made of Robinia - very durable acacia wood, resistant to weather conditions,
- Platforms and steps made of durable anti-slip and waterproof HPL plate,
- Side panels made of Robinia - very durable acacia wood without sharp edges, resistant to weather conditions
- Slides made of stainless steel,
- Colorful elements made of durable HPL plate, resistant to weather conditions,
- Telescope made of stainless steel and durable HDPE plate, resistant to weather conditions,
- Steel ropes in polypropylene braid, connected with durable plastic elements, stainless steel or aluminum,
- Calibrated stainless steel chains, preventing fingers entrapment,
- Handles made of steel rope in polypropylene braid,
- Screws covered with plastic caps and/or stainless steel screws,



Facilitating disability



easy access



handrails



integration



Intellectual development



manipulation



thinking



Physical development



sliding



observation



community



climbing





1 number of towers



1 number of slides



stairs

Product technical sheet

ROBINIA RB1308

Product data

Length	290 cm
Width	225 cm
Total height	280 cm
Age group	1+ years
Number of users	5 kids
Safety zone	23,2 m ²
Free fall height	90 cm
The height of the platforms	90 cm
slide platform height	90 cm
In accordance with norm EN	1176-1:2017+A1:2023
Weight of the heaviest part	81 kg
Dimensions of the largest part	350x18x18 cm
Availability of spare parts	YES
Installation time	3,5 h

Data is subject to change without prior notice.

Additional information

- equipment adapted for the disabled; intended for public playgrounds;
- equipment has a certificate issued by an accredited entity or a declaration of conformity;
- no sharp edges or chinks that would pose a danger of jamming the head, fingers or any other body parts;
- anchoring on flat surface, 80/70/60 cm deep;
- slide should not be installed southwards;
- render is for reference only, the actual appearance of the equipment and its color may vary;

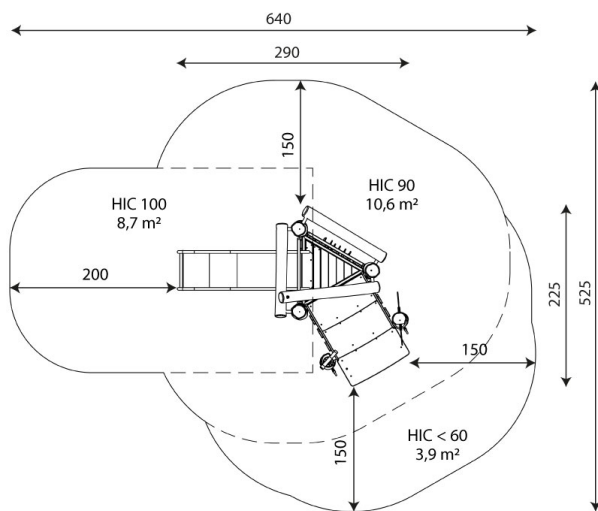

23,2 m²

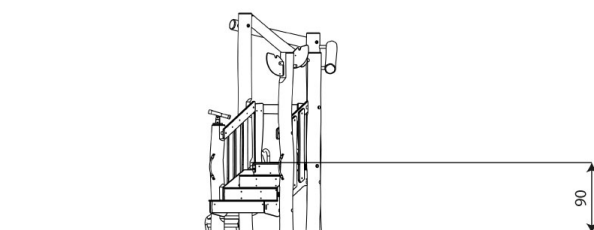
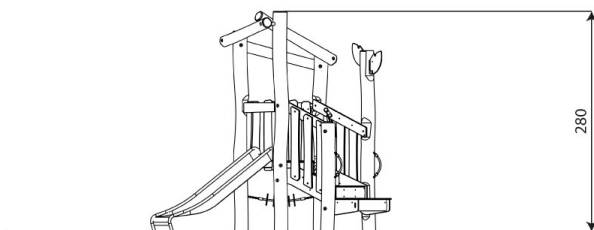

Guarantee

30

30 year guarantee - Durability of steel and stainless steel structural elements

15

15 year guarantee - Durability of steel and stainless steel structures of mobile devices; durability of Robinia wood structural elements

10

10 year guarantee - Structural strength of HDPE, 100% recycled HDPE and HPL elements; structural elements made of 100% recycled material (composite)

5

5 year guarantee - Corrosion resistance of stainless steel and hot-dip galvanized and powder-coated steel elements, resistance to bark beetles and rotting of wooden structural elements

Detailed information in the guarantee card



Surfaces according to EN 1176-1:2017+A1:2023

	Description (mm)	Layer thickness (cm)	Maximum fall heights (cm)
Turf/ top layer of soil (A,B,C)	-	-	≤100
bark (A,C)	Particle size from 20 to 80	30	≤200
		40	≤300
woodchips (A,C)	Particle size from 5 to 30	30	≤200
		40	≤300
sand or gravel (A,C)	Particle size from 0,25 to 8	30	≤200
		40	≤300
synthetic attested (A,B,C)	Tested according to EN 1177		100

Product technical sheet

ROBINIA RB1308

Amount of safe surface corresponding with free fall height:

HIC <60	3,9 m ²
HIC 90	10,6 m ²
HIC 100	8,7 m ²

Data is subject to change without prior notice.

