

# Uno Climber

PCM81021

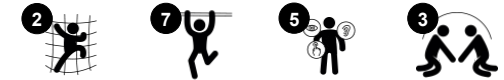

Item no. PCM81021-0901	
<b>General Product Information</b>	
Dimensions LxWxH	121x289x240 cm
Age group	6+
Play capacity (users)	5
Colour options	



The Uno Climber is a playground favorite with school children. They are immediately attracted to the dense, versatile activity hub. Thanks to the varied climbing opportunities with hanging bars, rope ladders and stable climbing wall with cleats and climb-through-hole, all children have a chance of doing something. The openness in design also invites conversation and social

interaction across the Uno Climber. This supports children's socio-emotional development and invites all in. With its combination of activities, the Uno Climber stimulates children's cross-coordination, strenght and bone density. All of these abilities are built for life in childhood. So the more they play, the more they gain.

# Uno Climber

PCM81021



Main posts with hot dip galvanized steel footing are available in different materials: Pressure impregnated pine wood posts. Pre-galvanized inside and outside with powder coated top finish steel posts. Lead free aluminum with color anodized top finish. Greenline TexMade posts of 100% post-consumer recycled PE and textile waste.

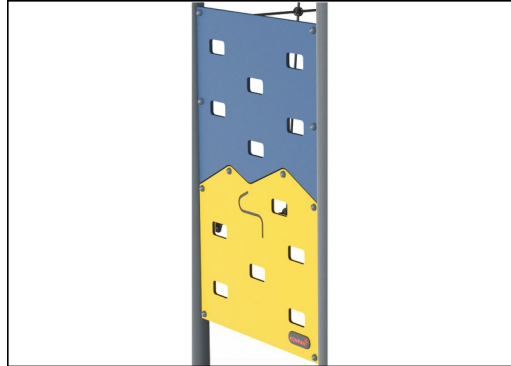

Panels of 19mm EcoCore™. EcoCore™ is a highly durable, eco friendly material, which is not only recyclable after use, but also consists of a core produced from 100% recycled post consumer material from food packing waste.

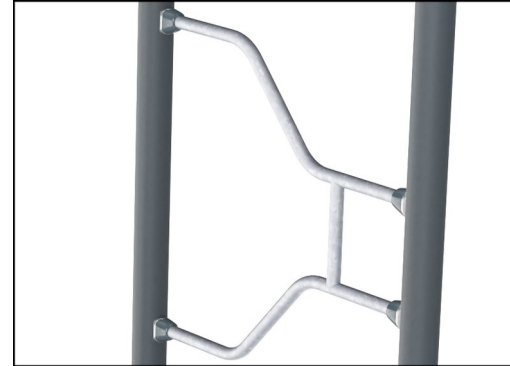

The steel surfaces are hot dip galvanised inside and outside with lead free zinc. The galvanisation has excellent corrosion resistance in outside environments and requires low maintenance.



Ropes are made of UV-stabilized PES rope strands with inner steel cable reinforcement. The polyester wrapping is inductively melted onto each strand to obtain excellent wear and tear resistance.



KOMPAN GreenLine versions are designed with ultimate environmentally friendly materials with lowest possible CO2e emission factor. TexMade post, EcoCore™ panels of 100% post consumer recycled ocean waste and molded PP decks.

Item no. PCM81021-0901

### Installation Information

Max. fall height	223 cm
Safety surfacing area	28.0 m <sup>2</sup>
Total installation time	4.9
Excavation volume	0.91 m <sup>3</sup>
Concrete volume	0.38 m <sup>3</sup>
Footing depth (standard)	90 cm
Shipment weight	176 kg
Anchoring options	Surface ✓ In-ground ✓

### Warranty Information

Hot dip galvanised steel	Lifetime
EcoCore HDPE	Lifetime
Post	10 years
Ropes & nets	10 years
Spare parts guaranteed	10 years





Cradle to Gate A1-A3	Total CO <sub>2</sub> emission	CO <sub>2</sub> e/kg	Recycled materials
	kg CO <sub>2</sub> e	kg CO <sub>2</sub> e/kg	%
PCM81021-0901	369.80	2.81	53.70
PCM81021-0950	273.50	1.62	76.50

The overall framework applied for these factors is the Environmental Product Declaration (EPD), which quantifies "environmental information on the life cycle of a product and enable comparisons between products fulfilling the same function" (ISO, 2006). This follows the structure and applies a Life-Cycle Assessment approach to the entire Product stage from raw material through manufacturing (A1-A3))

**Kompan A/S**  
 C.F. Tietgens Boulevard 32C  
 DK-5220 Odense SØ  
 Denmark



### Validation of CO<sub>2</sub> calculation of: Freestanding play equipment



Data version no. 2021-09-27

The CO<sub>2</sub> calculation and data are in compliance with the principles of a carbon footprint impact according to the GHG protocol (Greenhouse Gas Protocol), Scope 3, cradle to gate related to all individual components in the product category: "Freestanding play equipment" represented by item no.: GXY916012-3417.

(Scope 3 emissions include emission sources in the upstream and downstream value chain).

**Date: 15. October 2021 | Valid until: 15. October 2023**

**Validated by:**

Bente Hviid, Senior Consultant

Peter Bendtsen, Senior Consultant

Validation based on report: Validation of CO<sub>2</sub> calculation of 8 categories of Kompan product line, version 1.0, prepared by: Bureau Veritas HSE, Denmark: Bente Hviid and Peter Bendtsen.

**Publication date: 15. October 2021**

**By Bureau Veritas HSE**  
 www.bureauveritas.dk  
 +45 7731 1000



# Uno Climber

PCM81021

\* Max fall height | \*\* Total height | \*\*\* Safety surfacing area

\* Max fall height | \*\* Total height

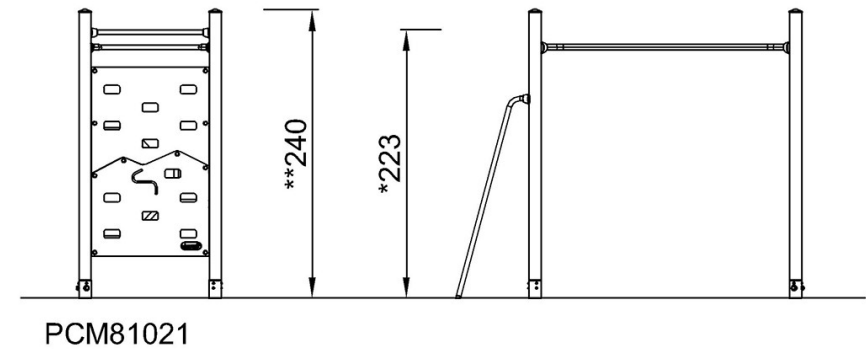
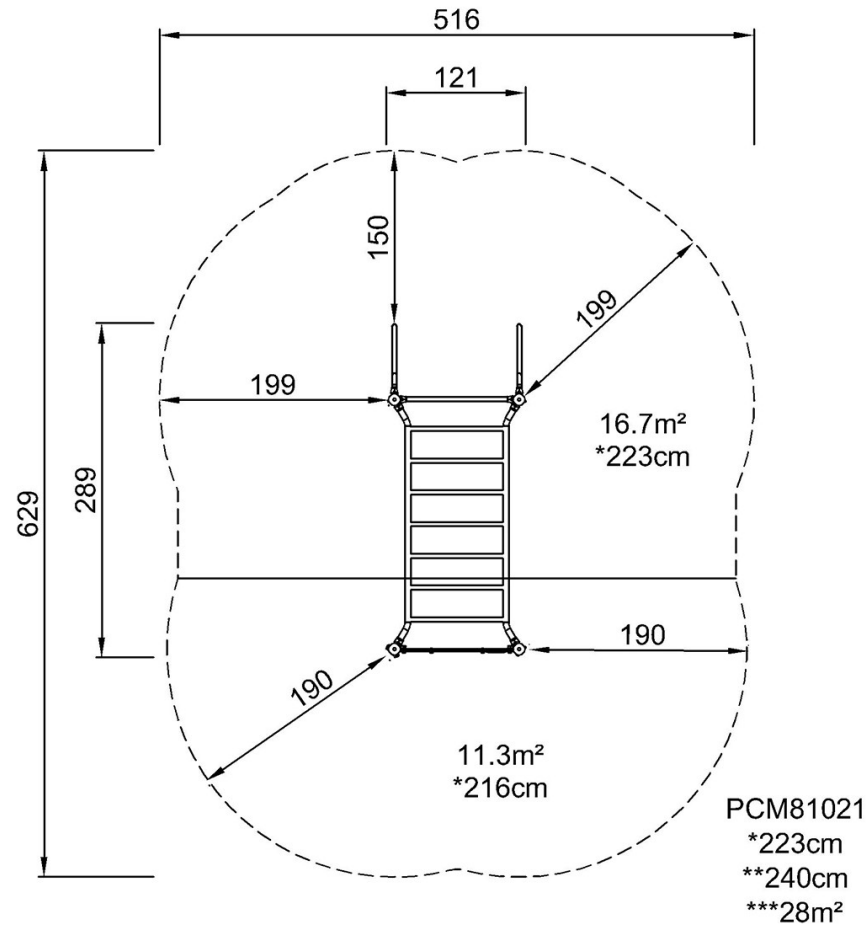

[Click to see TOP VIEW](#)

[Click to see SIDE VIEW](#)