

NRO2006

Double tower with spider net ADA

KOMPAN[®]
Let's play



This double tower invites a multitude of physical play activities: the spider net rooms many and is challenging with all the inclined rope steps. The platform can be entered via the net opening or the accessible stairway. From the highest level, the child can choose between a slide down or the supportive curly climber: the curly climber provides a good grip and a good seating support. It's designed to allow for children with walkers or wheelchairs either playing at the table or using the stairway. The product is available as FSC[®] Certified (FSC[®] C004450) robinia wood on request.

Product Line	Organic Robinia
Category	Multi play structures
Age group	3 - 10
Max. fall height (CM)	220
Total height (CM)	440
Safety Zone	53 m ²



IN-
GROU.



ASTM

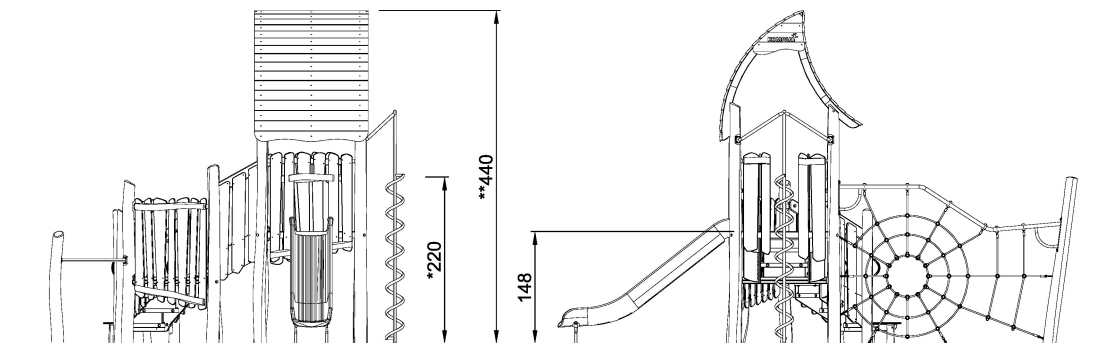
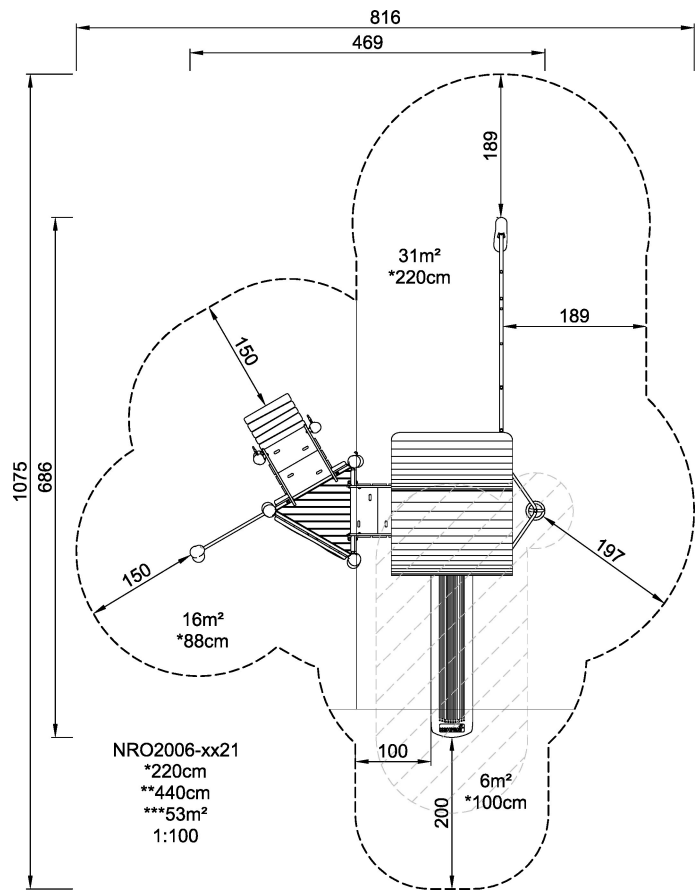

NRO2006
1:100

* = Highest designated play surface.
** = Total height of product.

Weight/heaviest parts	kg.	Installation (Manpower)	Persons
Concrete required	NaN m3	Installation (Hours)	Hours
Foundation amount/footing	NaN	Excavation	NaN m3