



Item no. PCE610121-0901	
General Product Information	
Dimensions LxWxH	1891x1608x582 cm
Age group	4+
Play capacity (users)	81
Colour options	



McKinley is an awesome play challenge, inviting all kids and attracting them back again and again, thanks to its impressive play opportunities at various levels. Ample thrilling and responsive climbing and balancing activities train the motor skills' ABC: Agility, Balance and Coordination. These are fundamental life skills for managing in today's

world with spatial awareness, for example, vital in road safety. The high, high net bridge and the wild semi-open slide offer exhilarating play rewards after having increased self-esteem in conquering new heights. There is 360° climbing throughout the transparent, bouncy and sturdy play unit. Numerous nooks and crannies and meeting points create areas for social

interaction. The high number of ground based features offers opportunities for all abilities to explore and enjoy.



Membrane climber

Physical: cross coordination and muscle strength when climbing up the bouncy, rubbery membrane climber, assisted by climbing cleats or just the hands. Gliding down supports spatial awareness. **Social-Emotional:** the two rows of cleats allow for parallel play and cooperation. **Cognitive:** the two rows of cleats invite rules play and competition.



Banister bars

Physical: coordination is supported when going down, as well as arm and core muscles. Landing strengthens bone density, which is built for life in childhood. **Social-Emotional:** turn-taking and risk-taking.



Pods track

Physical: children develop agility, balance and cross coordination when crawling, running or jumping from pod to pod. Jumping builds bone density. **Social-Emotional:** the pods invite a seated break for socializing.



Curved slide

Physical: sliding develops spatial awareness and a sense of balance. Furthermore, the core muscles are trained when sitting upright going down. **Social-Emotional:** empathy stimulated by turn-taking.



Wobble bridge

Physical: sense of balance and space, and training of posture. Important for being able to sit still. **Social-Emotional:** cooperation, turn-taking and friendly competition on the plates.



Play shell

Physical: the swaying movement stimulates the sense of balance, necessary to sit still on a chair. **Social-Emotional:** meeting, taking a break and turn-taking are supported, skills necessary to learn how to avoid conflicts.



Twisted net

Physical: the big, twisted meshes allow for varied climbing and crawling through, supporting the development of proprioception, spatial awareness, cross coordination, and muscle strength. **Social-Emotional:** the partly horizontal meshes allow more children to sit together and talk.

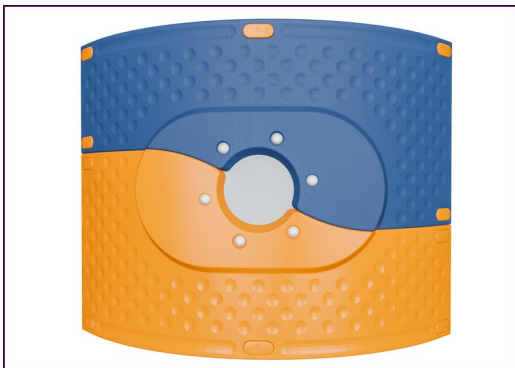

The Curved ELEMENTS panels are moulded of UV stabilised recyclable PE using 33% post-consumer recycled material. With multiple options for in-build play features that also ensures a strong panel solution. Straight panels are made of KOMPAN 19mm HDPE EcoCore™ which is a highly durable, ecofriendly and recyclable material made from +95% PCM.



The climbing elements displayed are moulded from 33% post-consumer recycled materials in one piece, with a minimum 5mm wall thickness. The climbing elements are made of recyclable PE which has a high impact resistance across a wide temperature span which ensures vandal resistance in all locations.

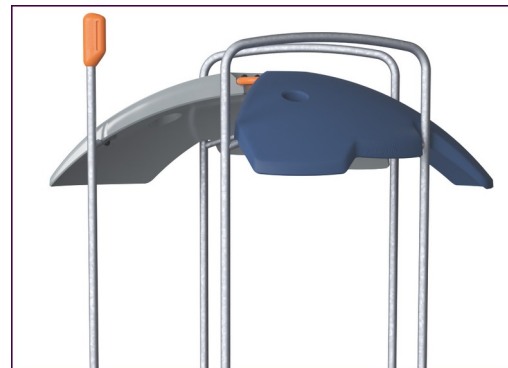

The ELEMENTS roofs are made of recyclable PE made from 33% post consumer recycled materials with a minimum wall thickness of 5 mm to ensure high durability in all climates around the world. The steel pipes are hot dip galvanised inside and outside for maximum durability.



The main posts are made of high quality pregalvanized steel with powder coated top finish. Post tops are closed with caps of UV stabilized nylon (PA6). The grey colored molded decks are made of 75% post-consumer waste PP material with a non-skid pattern and texture surface. All decks are supported by unique designed low-carbon aluminum profiles with multiple attachment options.



ELEMENTS rubber membranes are conveyor belt made of layers of rubber mixed of natural rubber and SBR rubber, and embedded with layers of armouring made of woven PE and PA. The thickness 8mm ensures high durability in any environment.



ELEMENTS ropes has six-stranded steel wires and a steel wire core. Each strand is tightly wrapped with PES yarn, which is made from +95% post consumer materials. The yarn is then melted onto each individual strand making the ropes highly wear- and vandalism-resistant.

Item no. PCE610121-0901

Installation Information

Max. fall height	278 cm
Safety surfacing area	211.0 m ²
Total installation time	93.9
Excavation volume	2.92 m ³
Concrete volume	0.37 m ³
Footing depth (standard)	85 cm
Shipment weight	3,924 kg
Anchoring options	Surface ✓ In-ground ✓

Warranty Information

Curved panels	10 years
EcoCore HDPE	Lifetime
Membrane	2 years
Post	10 years
Spare parts guaranteed	10 years



Sustainability Data

PCE610121



Cradle to Gate A1-A3	Total CO ₂ emission	CO ₂ e/kg	Recycled materials
	kg CO ₂ e	kg CO ₂ e/kg	%
PCE610121-0901	8,292.13	2.71	51.43

The overall framework applied for these factors is the Environmental Product Declaration (EPD), which quantifies "environmental information on the life cycle of a product and enable comparisons between products fulfilling the same function" (ISO, 2006). This follows the structure and applies a Life-Cycle Assessment approach to the entire Product stage from raw material through manufacturing (A1-A3))

Kompan A/S
 C.F. Tietgens Boulevard 32C
 DK-5220 Odense SØ
 Denmark



Verification of CO₂ calculation of: Play systems



Data version no. 2023-10-05

The CO₂ calculation and data are in compliance with the principles of a carbon footprint impact according to the GHG protocol (Greenhouse Gas Protocol), Scope 3, cradle to gate related to all individual components in the product category: "Play systems" represented by item no.: PCM200321-0950.

(Scope 3 emissions include emission sources in the upstream and downstream value chain).

Date: 30. October 2023 | Valid until: 30. October 2025

Verified by:

Julie Marie Vejsgaard Larsen, LCA & EPD Consultant

Verification based on report: Validation of CO₂ calculation of 9 categories of Kompan product line, version 1.0, prepared by: Bureau Veritas HSE, Denmark: Julie M. V. Larsen.

Publication date: 30. October 2023

By Bureau Veritas HSE
 www.bureauveritas.dk
 +45 7731 1000



* Max fall height | ** Total height | *** Safety surfacing area

* Max fall height | ** Total height

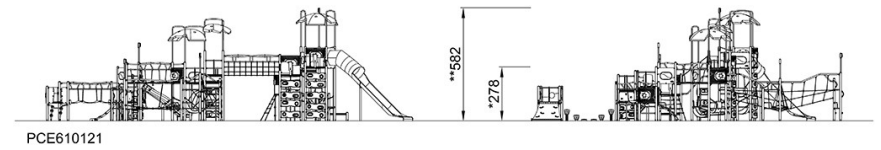
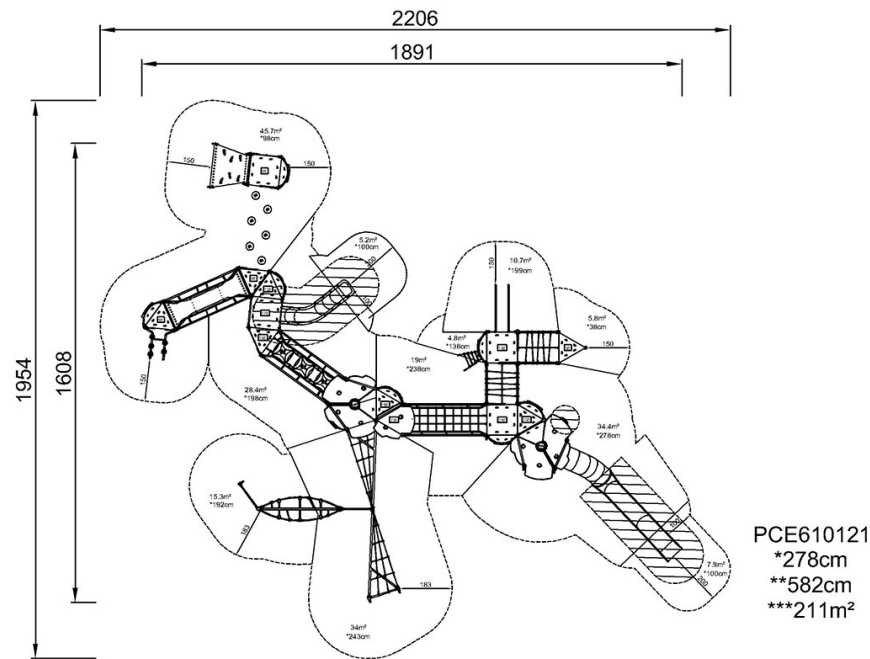

[Click to see TOP VIEW](#)

[Click to see SIDE VIEW](#)